

# Planmed Verity®



# Compact and versatile CBCT device



## Planmed Verity® – the world's first CBCT scanner for weight-bearing orthopedic imaging

3D extremity imaging under natural load provides invaluable information for the orthopedists for treatment planning.

Planmed Verity® CBCT scanner is the first computed tomography system designed for weight-bearing imaging.

## Enhanced fracture diagnostics with low dose 3D imaging

Even up to 30% of scaphoid fractures may be missed or not visible in 2D radiographs after trauma. Delayed fracture diagnosis can lead to osteonecrosis, a severe condition often requiring surgery and a bone graft.

Planmed Verity provides high-resolution, low dose 3D imaging for improved fracture diagnostics at the point-of-care.

## Versatility with head and neck imaging

Planmed Verity CBCT scanner can be equipped for head and neck imaging. Maxillofacial and dental scans will add significant versatility and fast return on investment (ROI).

## Planmed – leading the way in medical CBCT

Cone-beam computed tomography (CBCT) has been the mainstream in dentistry for decades, but in medical imaging the adoption has taken more time. With the world's first orthopedic CBCT scanner, Planmed leads the way in medical CBCT.

# Accurate diagnosis with 3D imaging



## High-quality images with a low patient dose

CBCT technology with a flat panel sensor allows for a significantly lower radiation dose than that of conventional CT scans (MDCT). One high-resolution CBCT scan utilizes similar dose levels to those commonly used in 2D X-ray extremity imaging studies. This corresponds to less than a week's amount of naturally occurring background radiation.

Isotropic, high-resolution 3D voxels show bone structures with unprecedented detail. Multiplanar reconstruction (MPR) provides optimal visualization without overlapping structures, and the true anatomy and orientation of the bones is easy to understand from the surface rendered images.

## Optimal diagnosis and treatment plan

Thanks to the **Planmed Verity® OneScan** imaging technology with the dedicated patient positioning and automated correction algorithms, technicians can avoid unnecessary retakes and excess dose. Radiologists can rely on the volumetric image dataset and focus on the diagnostic work.

## Intelligent implant processing

The intelligent removal algorithm for metal artifacts (MAR) ensures the maximum visibility of implants, fixators, or metal prostheses, and the bone surrounding them.

## Movement artifact correction

Planmed Verity with **Planmeca CALM™** can correct any patient movement. This revolutionary algorithm eliminates motion artifacts from CBCT images, making it invaluable for pediatric, weight-bearing, or complex patient exams.

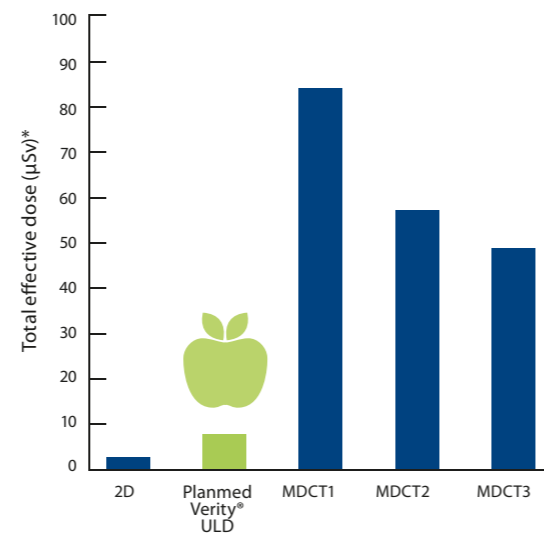

## Ultra low dose 3D imaging

The pioneering **Planmeca Ultra Low Dose™ (ULD)** examination protocol guarantees CBCT examinations at a significantly lower dose than those of conventional CT scans without reducing the diagnostic quality of the examination.

## Maximum patient comfort

The **Planmed Verity®** scanner is equipped with a motorized gantry adjustable in both height and tilt for the ideal patient positioning. With the anatomically designed carbon fiber positioning trays, the target is always within the imaging volume.

Thanks to the micrometric adjustments of the gantry, the patient is positioned correctly for each type of diagnostic exam. While capturing the exam, the patient can relax and lean on the soft and comfortable gantry, which reduces discomfort and movement during the scan.



\*Koivisto, J., Kiljunen, T., Wolff, J. and Kortenesniemi, M: Assessment of effective radiation dose of an extremity CBCT, MSCT and conventional X ray for knee area using MOSFET dosimeters. Radiat. Prot. Dosim. Advance Access published July 3, 2013, doi: 10.1093/rpd/nct162

# Compact and portable CBCT device

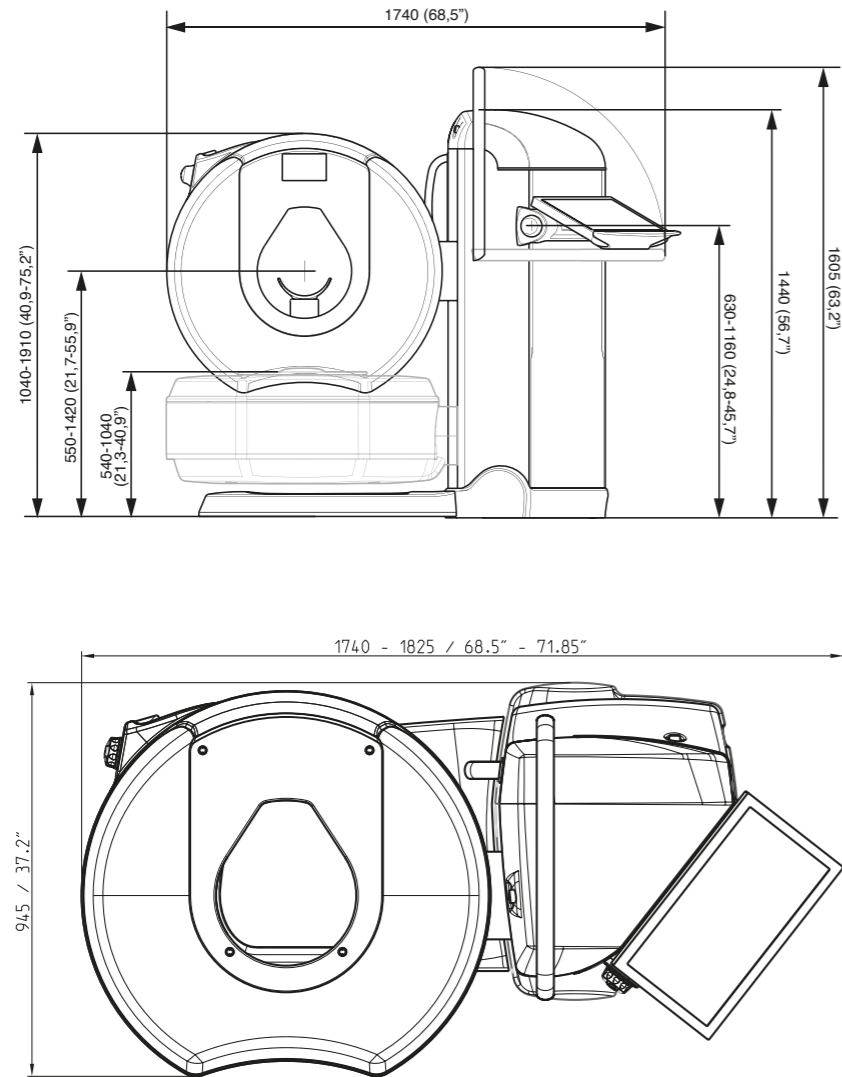

## Easy set-up

Planmed Verity® can be placed in virtually any room with minimum requirement for shielding, even alongside other existing equipment. The Planmed Verity portable system is always ready for use under all circumstances.

When setting up the unit, it is not necessary to prepare a large space or have external cooling systems. The standalone unit requires only a standard mains power supply and an Ethernet connection to start capturing astounding high-resolution 3D images with a low dose.

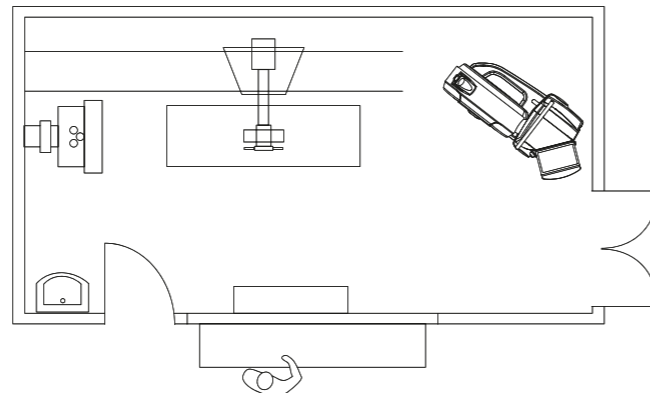

## Connectivity

The Planmed Verity® Manager software is equipped with integrated image transfer protocols and a patient list to communicate with the Hospital Information System (HIS), the Radiology Information System (RIS), and the Picture Archive and Communications System (PACS). Planmed Verity Manager is fully compatible with the DICOM protocol.

## Supported DICOM service classes

- Modality Worklist
- Storage
- Query/Retrieve
- Print
- Radiation dose structure report (RDSR)
- Modality performed procedure step (MPPS)

# Easy positioning

## Dedicated positioning system

Dedicated positioning trays and a positioning camera ensure that the area of interest is always in the center of the field of view (FOV). The positioning system helps in achieving the correct anatomical orientation of the extremity to support image interpretation and diagnosis.

## Intuitive control interface

Planmed Verity® is equipped with an intuitive one-hand control system for both gantry and tray movements. The user can comfortably operate the device in a precise and simple way while positioning the patient.

## Optimal visibility of the anatomical region to be examined

The extended TearDrop™ opening of Planmed Verity offers excellent visibility and access to the patient from both sides of the gantry, eliminating the feeling of anxiety and claustrophobia. The image volume is indicated with automatically activating red and green lasers, and a video camera shows the target on the multifunction monitor located on the gantry of the machine.

## Workflow optimization with the touch screen

The user-friendly GUI, optimized for the latest generation touch screen, guides the user through the procedure of performing the exam. The pre-set and user-configurable imaging programs ensure a smooth workflow and simple operation. There are multiple tools and software features that can easily be selected from the touch screen for image processing, section thickness definition, surface rendering, and much more. The Planmed Verity touch screen is adjustable both in height and tilt to optimize the workflow and ergonomics.

## Upper extremities

- Elbow
- Arm
- Wrist
- Hand
- Fingers

## Lower extremities (with the possibility of weight-bearing examinations)

- Knee
- Leg
- Ankle
- Foot
- Toes

## Head and neck

- Face
- Dental Arch
- TMJ
- Neck
- Sinuses
- Teeth



# Top-quality articular imaging in 3D



Non-weight-bearing

Weight-bearing

3D weight-bearing



## Weight-bearing CBCT

One of the most revolutionary applications of **Planmed Verity®** is the weight-bearing imaging of the lower joints. It is possible to tilt the gantry to a horizontal position, so that the patient can stand inside the gantry while capturing the images.

Imaging a standing patient shows the anatomy under natural load, which helps in highlighting the possible areas of contact (impingement) that would otherwise remain hidden or doubtful in a non-weight-bearing position. This improves the diagnostics and increases the predictability of treatments.

Comparison exams between the sitting and weight-bearing positions are beneficial for examining the changes in great detail with superb 3D image quality.

# Advanced imaging

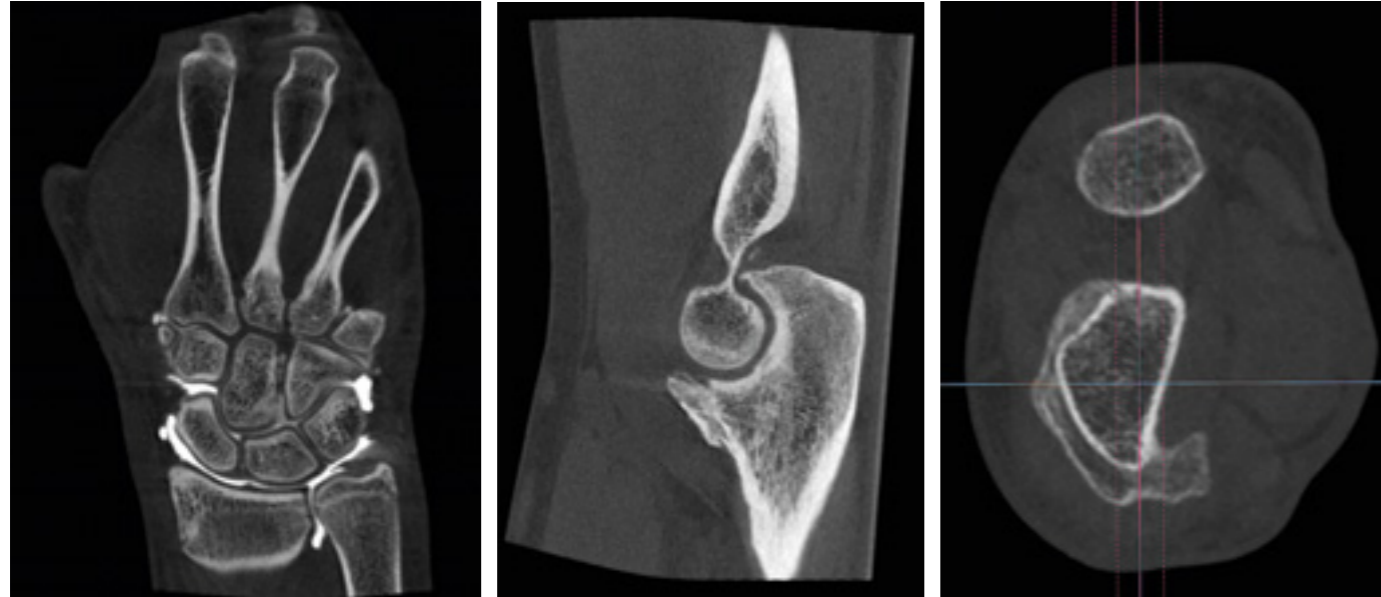

## Quick reconstruction of 3D images

Iterative 3D reconstruction takes place in real time. During the reconstruction process, the patented image processing algorithms refine the image for an optimal presentation of clinically relevant data.

DICOM images are automatically archived to PACS after the scan and are available for review on all workstations on the network.

## Stitching

It is also possible to extend the volume scanned, if needed. This option, called the stitching algorithm, combines images into a single volume and is useful in viewing anatomies that require an extended imaging volume.

## Artifact removal

The advanced artifact removal algorithms ensure high-quality images, even for very complex cases. With optimal processing, the details of the bone structure up to the bone/metal interface are easily discernible. This is invaluable for post-operative imaging and joint surface evaluation.

## Other applications

Planmed Verity® enables several new and fascinating applications. For example, the bone healing process can be evaluated without removing the cast, which has led to shorter immobilization times. It is also possible to use contrast media for arthrography or other specialized imaging techniques. By combining a low radiation dose and easy access with high-quality clinical images, Planmed Verity has changed orthopedic imaging for the better.



# Planmed Verity® workstation with Planmeca Romexis® software

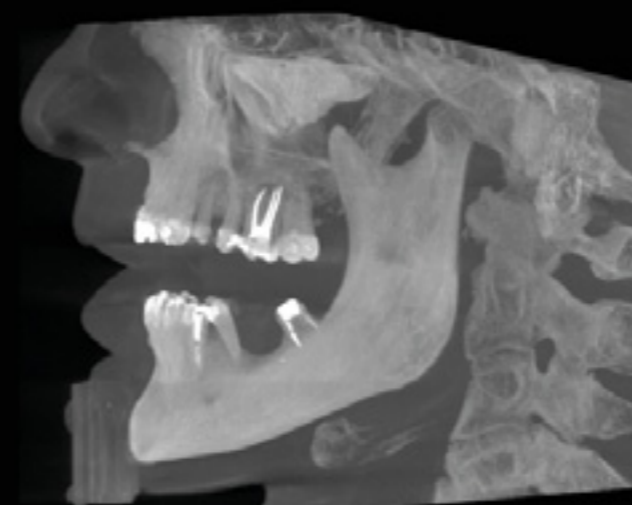
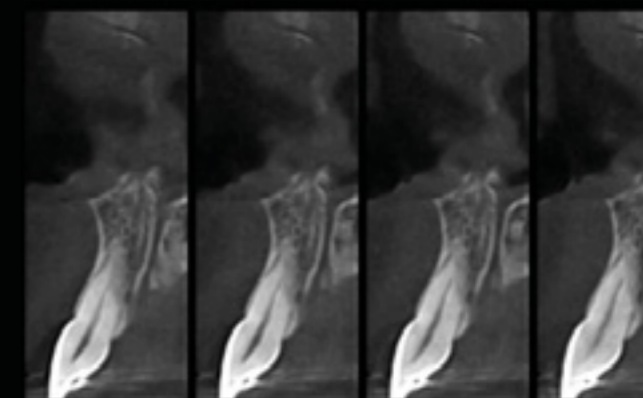
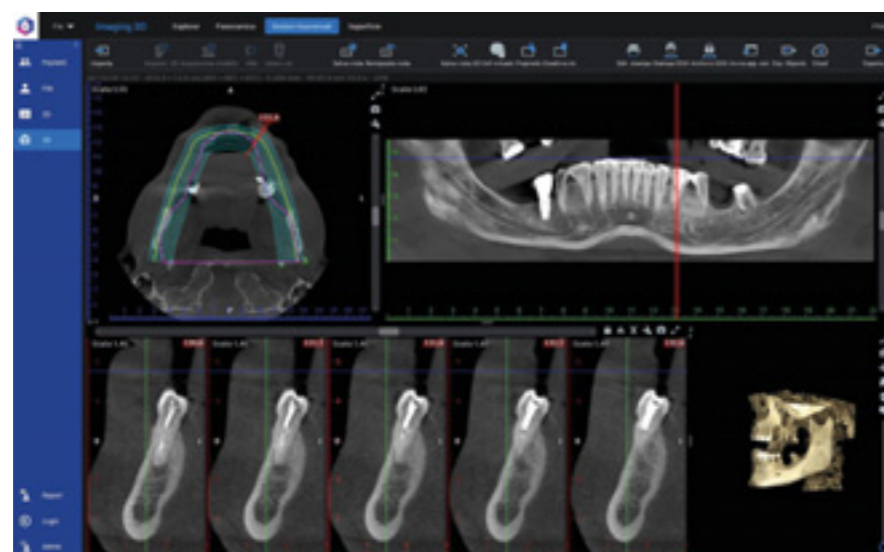
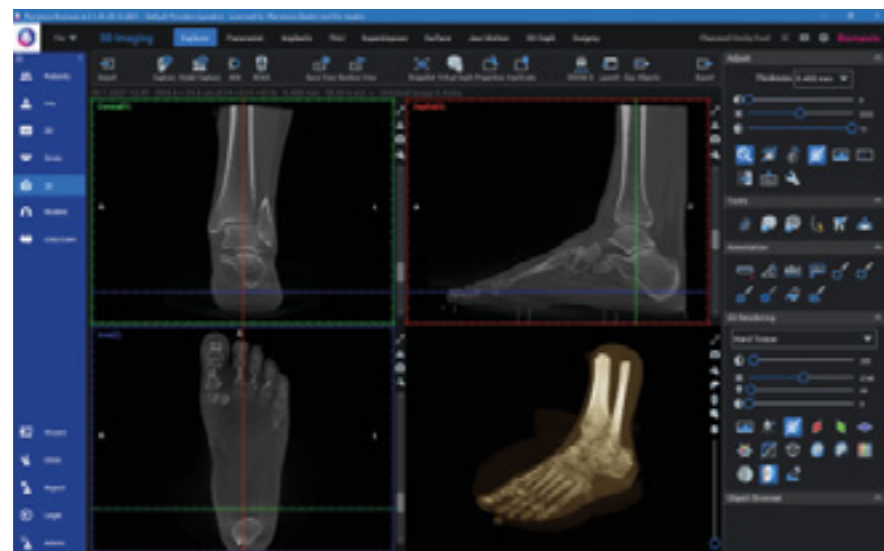

## Planmeca Romexis® Medical

Planmeca Romexis® Medical is a comprehensive software for viewing, processing and storing volumetric images for the Planmed Verity® CT scanner. Romexis Medical comes with full DICOM connectivity – images can be sent directly from Planmed Verity as volumetric data sets to any desktop PC or Mac. The images can also be automatically DICOM-stored to the PACS archive and, upon return visits, immediately retrieved to the Romexis Medical software.

Designed for dental imaging, Planmeca Romexis® enables the reconstruction of a panoramic image and cross-sectional images on any desired plane. Planmeca Romexis flexibly adapts to the needs of clinics of any size, and as it is a networked solution, all images are available on different workstations immediately.

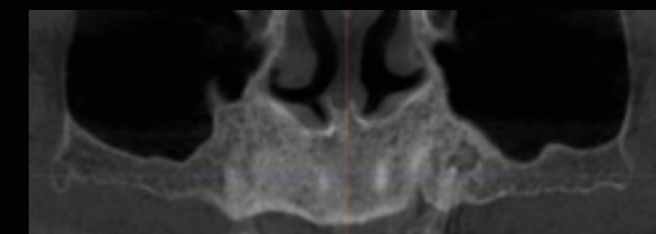
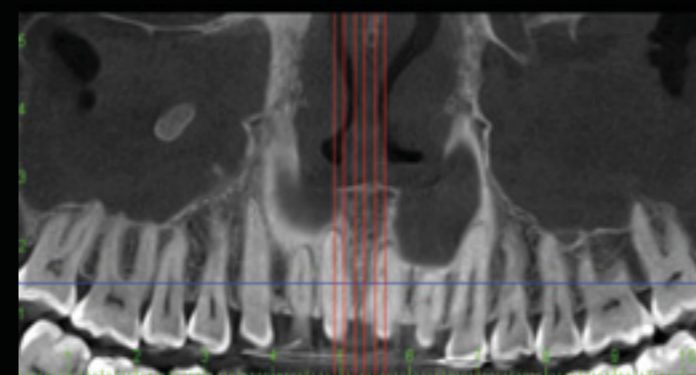





Meary's angle Alluce



Hallux valgus: 1-2 intermetatarsal line



Salzman view



"Until recently, CT images have been analyzed using the 2D slice view, as if you were looking at the image with one eye only. Cone beam CT imaging with the **Planmed Verity®** scanner and the Disior software allows analyzing the original 3D data in a way that compares to having a 20/20 vision."

– Professor **Jari Salo**, MD, Specialist in Orthopedics and Trauma, Mehiläinen medical clinic in Helsinki, Finland

## Simplify your clinical workflow

- Enjoy easy and safe transfers of DICOM and 3D data
- Analyze your CT or CBCT scans in 3–4 minutes saving hours of work
- Discover objective measures that can help you evaluate the degree of pathology and identify impingement points
- Virtually simulate the procedure and assess the generated post-operative measures to achieve improved treatment outcomes
- Visualize the findings and show the planned procedure to your patient
- Assess the treatment outcomes

## Diagnosis and treatment through true 3D vision

Disior's analytics software is a fast and cost-effective way to obtain reliable information from medical images in 3D. Each anatomy-specific module enables specialist clinicians to have the objective data needed for diagnosis, creating patient-specific surgical plans and assessing treatment outcomes.

Key benefits:

- **Accurate:** Accurate diagnosis with automated, easy-to-use tools without manual labor
- **Fast:** Optimized patient flow with reliable analysis
- **Better outcomes:** Improved treatment outcomes through patient specific surgery plans

The optional Disior modules to choose from include:

- Disior Bonelogic Hand & Wrist
- Disior Bonelogic Foot & Ankle
- Disior Bonelogic CMF Orbital Fracture

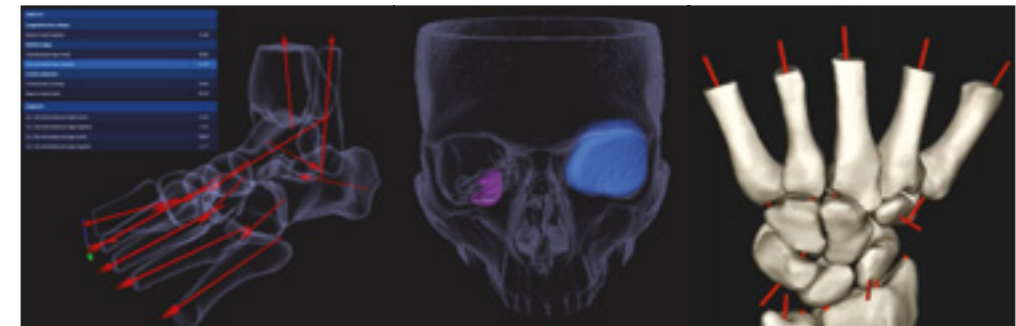

# Accessories



## Verity StackRack™ (optional)

Verity StackRack™ is a compact holder for all Planned Verity® patient positioning trays, including the weight-bearing tray for Planned Verity. It can be wall mounted, if needed.



# Configuration and set-up

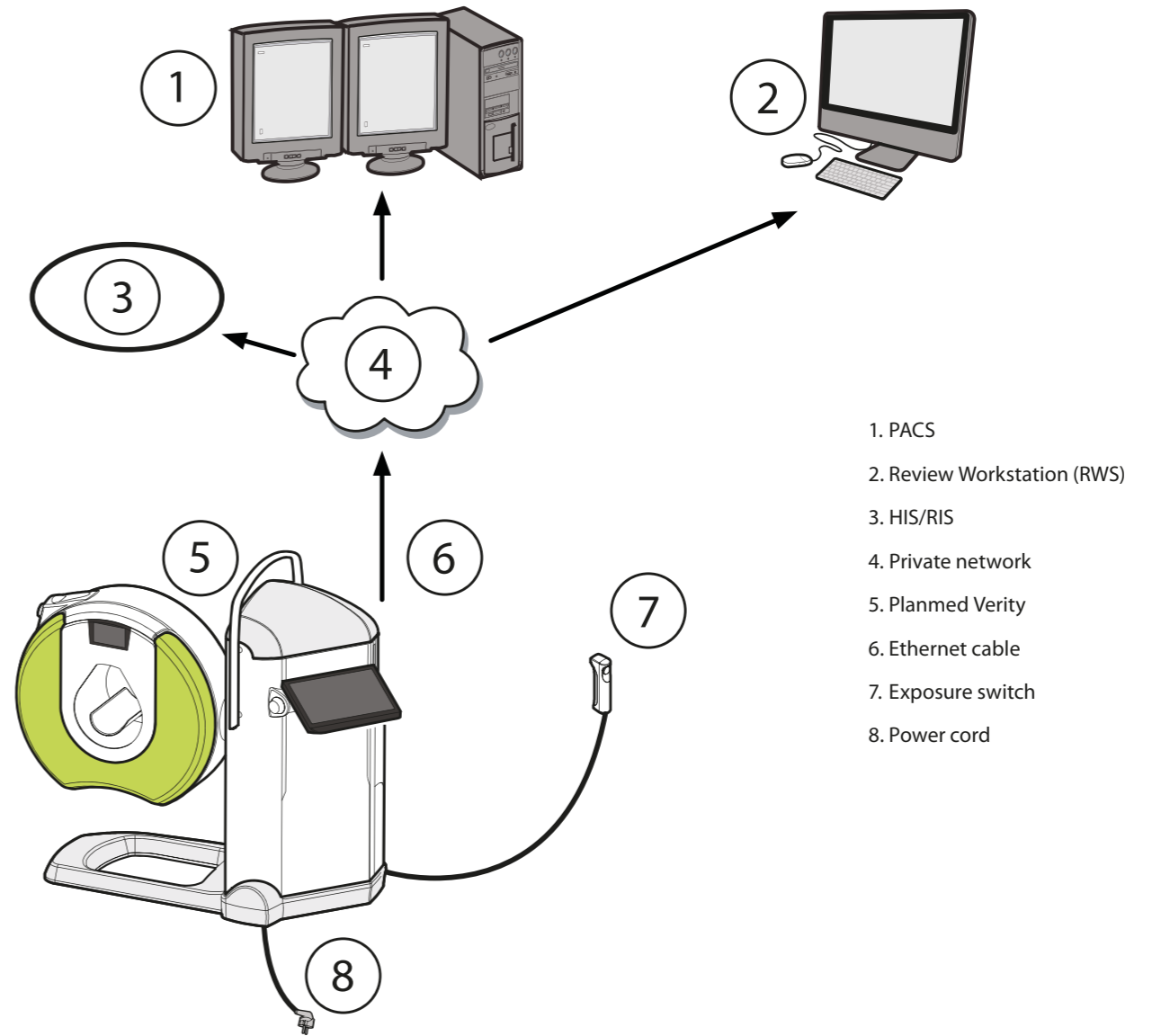

- 1. PACS
- 2. Review Workstation (RWS)
- 3. HIS/RIS
- 4. Private network
- 5. Planned Verity
- 6. Ethernet cable
- 7. Exposure switch
- 8. Power cord

# Technical specifications

Power: 80–96 Kv; 1–12 mA

Size: (WxLxH) 76x184x160cm

Weight: 350 kg

Multi FOV (Field of View): Up to 16x20 cm

Voxel Sizes: 200–400 um

Input: 100–240V single phase, 10–16A

Full DICOM compatibility

Planmed Verity® workstation (optional)

CE 0598  Planmed Verity

CE 0598  Planmeca Romexis



## Planmed

Planmed Oy | Sorvaajankatu 7 | 00880 Helsinki | Finland | tel. +358 20 7795 300 | fax +358 20 7795 664 | sales@planmed.com | www.planmed.com

